

Distributed by



English

# *Feed conservation in plastic bags*

## *Ensiling, conservation, storage*

ROTOR BAGGER  
PRODUCT OVERVIEW



**BUDISSA BAG®**  
BAG Budissa Agroservice GmbH



# ROTOR BAGGER RT 8000

“Standart Bagger” – for medium sized farms (at least 5.000 tons of silage per year)

## Basic equipment

- 2,40 m rotor, 2,70 m tunnel
- Feed table with rubber belt
- Double brake for pressure control
- Approved transport drawbar
- Two beater bars
- Steel back-stop
- Crane with mechanical winch
- Hydraulic cable rewind
- Wide tires
- CE-sign for EU safety standard
- Emergency stop for driving tractor

## Options

- 2,40 m or 3,00 m fix tunnel
- Exchange tunnel (2,40 m /2,70 m or 2,70 m / 3,00 m)
- Hydraulic tunnel clean-out
- Electrical winch
- Feed table side wall extension
- Foldable tunnel extension
- Applicator for silage additives
- Brake for approved transport drawbar (25 km/h)

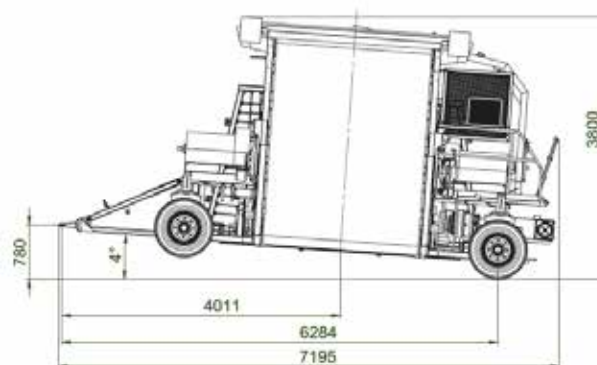

Technical Data	RT 8000
Weight	7.000 kg
Power requirement of tractor	160 HP
Usable bag sizes	2,40m (8') 2,70m (9') 3,00 m (10')
Performance (depends on feed)	up to 100 t/h





# ROTOR BAGGER RT 7000

“Farm Bagger” – for small to medium sized farms (at least 2.500 tons of silage per year)

## Basic equipment

- 2,10 m rotor, 2,40 m tunnel
- Feed table with rubber belt
- Single brake for pressure control
- I Approved transport drawbar (25 km/h)
- One beater bar
- Steel back-stop
- Mechanical cable rewind
- CE-sign for EU safety standard
- Emergency stop for driving tractor

## Options

- Crane with mechanical winch
- Brake for approved transport drawbar (25 km/h)
- Applicator for silage additives
- Compost-set



Technical Data	RT 8000
Weight	5.950 kg
Power requirement of tractor	80 - 130 HP
Usable bag sizes	2,40m (8')
Performance (depends on feed)	40 - 60 t/h



# ROTOR BAGGER RT 5000

“Baby Bagger” – for small farms (at least 1.000 tons of silage per year)

## Basic equipment

- 1,20 m rotor, 1,65 m tunnel
- Hopper (3,00 m width)
- Hydraulic wheel brake for pressure control
- Approved transport drawbar (25 km/h)
- One beater bar
- CE sign for EU safety standard

## Options

- Applicator for silage additives

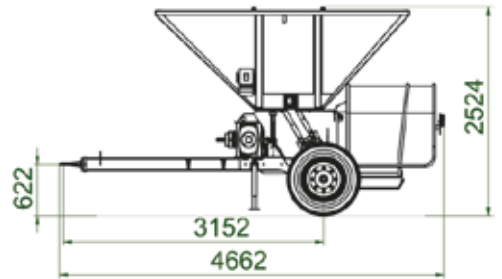

Technical Data	RT 8000
Weight	2.800 kg
Power requirement of tractor	80 - 100 HP
Usable bag sizes	1,65m (5,5')
Performance (depends on feed)	20 - 40 t/h



[www.arkor.com.tr](http://www.arkor.com.tr)  
[www.hayvancilikmarketi.com](http://www.hayvancilikmarketi.com)

Adress: Karacaoğlan Neighborhood 6157/3 Street N: 2/D 3507 Bornova - Izmir - Turkey

Tel: +90 850 455 1850

Fax: +90 850 455 1851

E-mail: [info@arkor.com.tr](mailto:info@arkor.com.tr)